

Surname	Centre Number	Candidate Number
Other Names		0



New GCSE

4461/02

**SCIENCE A
HIGHER TIER
BIOLOGY 1**

P.M. WEDNESDAY, 30 May 2012

1 hour

For Examiner's use only		
Question	Maximum Mark	Mark Awarded
1	6	
2	4	
3	7	
4	7	
5	6	
6	4	
7	4	
8	6	
9	9	
10	7	
Total	60	

ADDITIONAL MATERIALS

In addition to this paper you may require a calculator and a ruler.

INSTRUCTIONS TO CANDIDATES

Use black ink or black ball-point pen.

Write your name, centre number and candidate number in the spaces at the top of this page.

Answer **all** questions.

Write your answers in the spaces provided in this booklet.

INFORMATION FOR CANDIDATES

The number of marks is given in brackets at the end of each question or part-question.

You are reminded that assessment will take into account the quality of written communication used in your answer to questions **3** and **9**.

Answer all questions.

1. In cats, the allele for short hair (**D**) is dominant to the allele for long hair (**d**).

A cat with short hair was mated with a cat with long hair. All the offspring (**F1**) had short hair.



- (a) (i) Complete the following to show the genotypes of the parents. [1]
- I. The cat with short hair.
- II. The cat with long hair.
- (ii) Complete the Punnett square to show the cross between the cat with short hair and the cat with long hair. [2]

F1

Gametes		

- (b) (i) Complete the Punnett square to show the offspring produced on selfing (breeding together) two of the **F1** generation. [2]

F2	Gametes		

- (ii) Complete the following to show the ratio of the different types of offspring appearing in the **F2** generation. [1]

..... homozygous dominant: heterozygous: recessive

2. In 1982 the same species of pine tree was planted on both sides of a river valley in Wales. In 2011 the trees were surveyed at points **A**, **B** and **C** and the average heights of the trees were recorded.

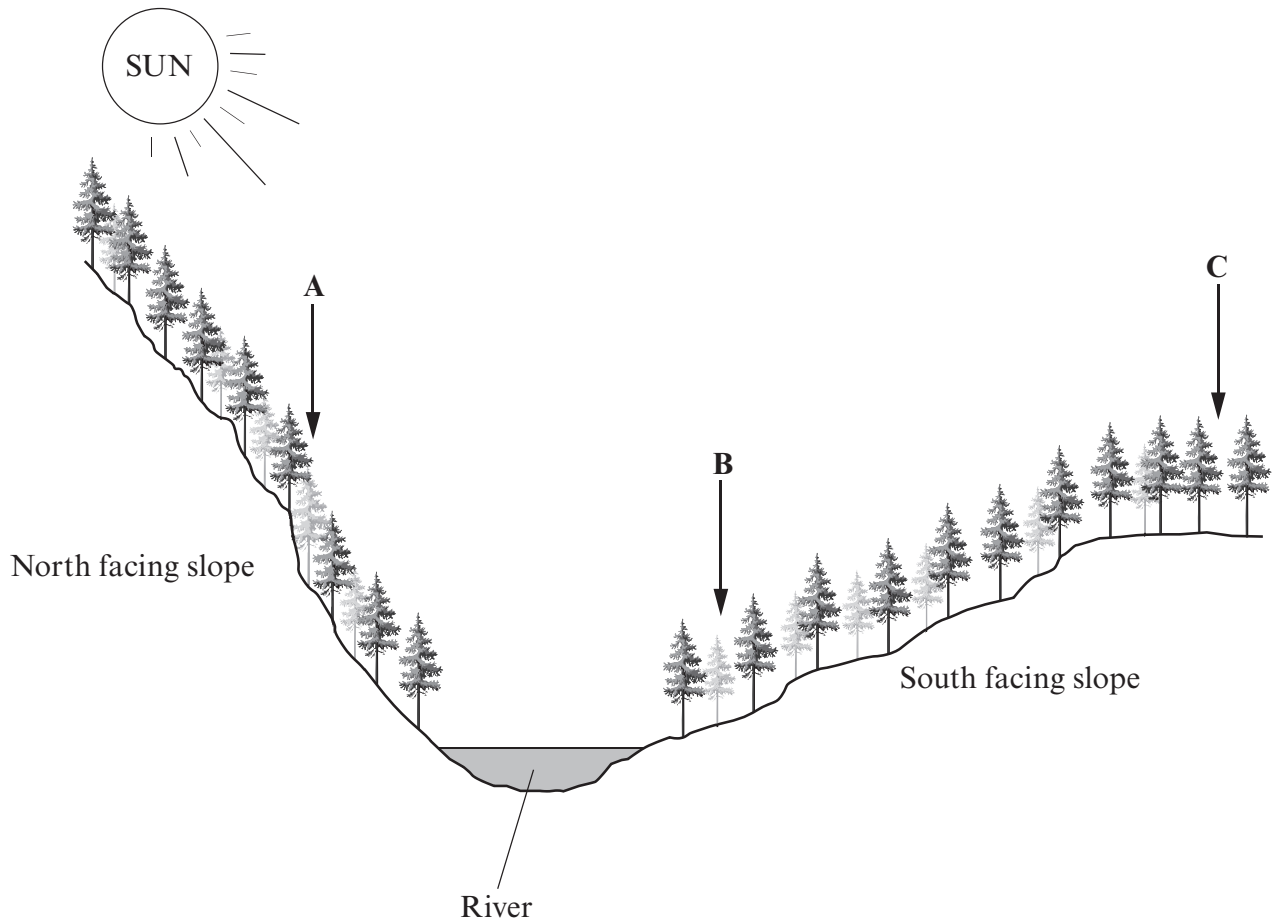

Table showing the average heights of the trees at survey points, **A**, **B** and **C**.

Survey point	Average height of trees (m)
A	8.6
B	11.4
C	10.7

(a) What term is used to describe the differences found between members of the same species? [1]

(b) Suggest **two** environmental reasons for the differences in the average height of the trees growing at survey points **A** and **B**. [2]

(i)

.....

(ii)

.....

(c) All the trees growing at survey point **C** were growing under exactly the same environmental conditions, but the difference in height between the individual trees was as much as 0.5 m. Suggest a reason for this difference. [1]

.....

3. The diagram shows a section through the skin.

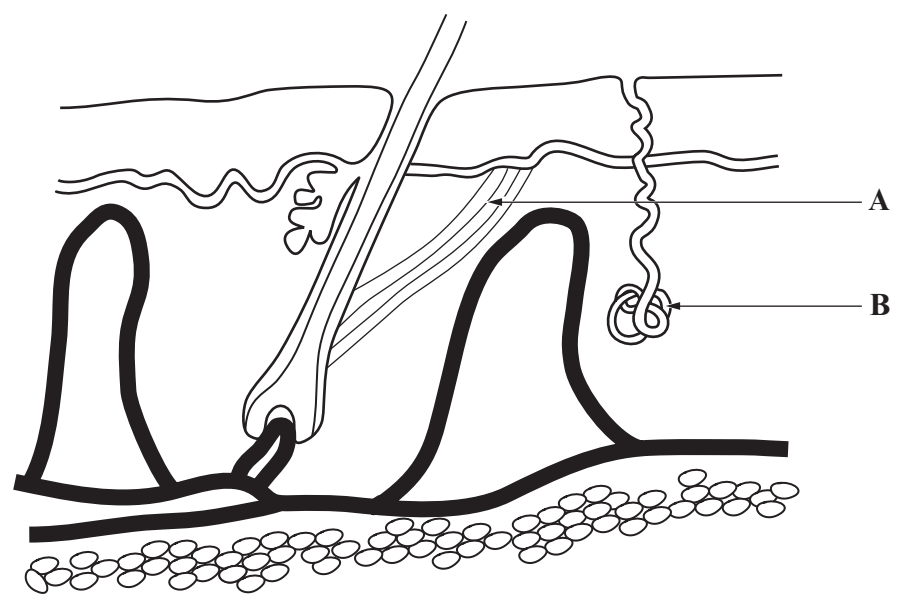

(a) Label part **A** on the diagram.

[1]

(b) Explain in detail the role part **B** plays in lowering the body temperature in warm conditions. [6 QWC]

.....

.....

.....

.....

.....

.....

.....

.....

.....

.....



BLANK PAGE

4. The information below shows the information on the packaging of two different breads, *Multi-Seeded* and *White sliced*.

	Multi-Seeded (100g)	White Sliced (100g)	Guideline Daily Amount (GDA) for an adult
Energy (kJ)	1110	992	8400
Protein (g)	10.5	9.5	45
Total carbohydrates (g)	33.5	15.7	230
Sugars (g)	4.1	4.2	90
Total fat (g)	9.9	1.3	70
Saturated fat (g)	1.5	0.1	20
Salt (g)	0.85	0.4	6

- (a) Use the information in the table to calculate the mass of a *White Sliced* loaf which an adult needs to eat to reach their GDA of energy. [2]

Answer

- (b) Which of the breads would you recommend to:

- (i) a person suffering from coronary heart disease; [1]

Bread

Reason

- (ii) a person suffering from high blood pressure? [1]

Bread

Reason

(c) Bethan wanted to check the energy content of the *Multi-Seeded* bread. She set up the apparatus shown below.

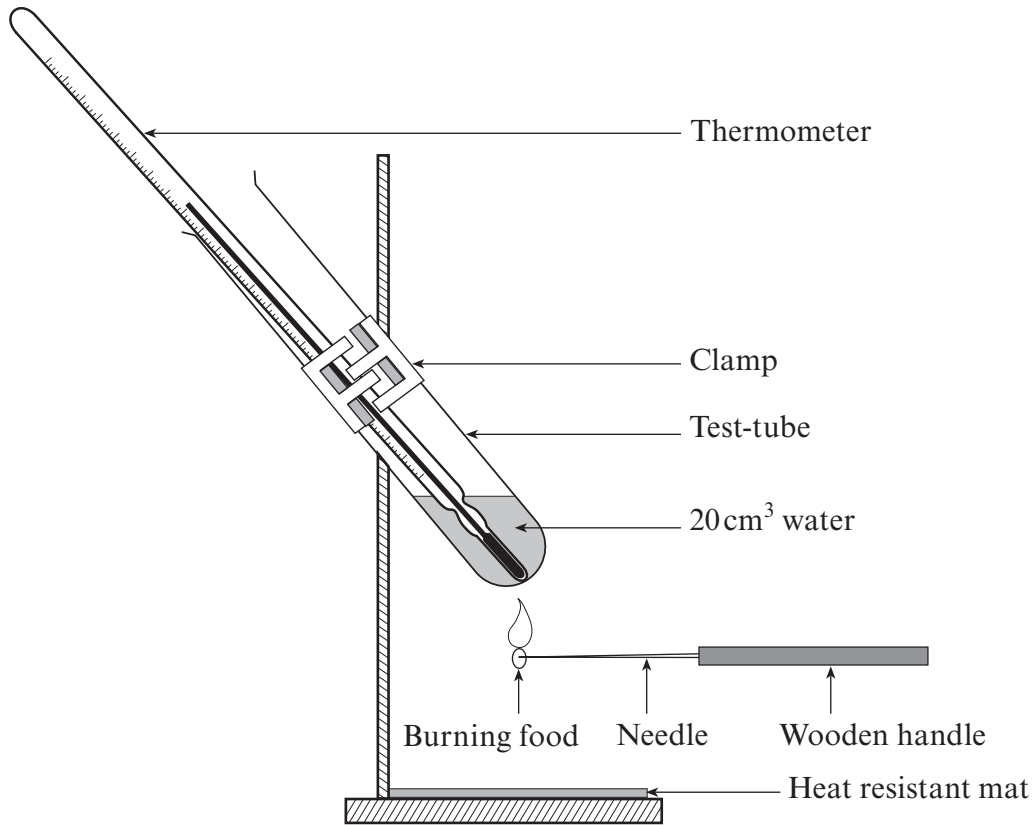

(i) Apart from the volume of water used, state **two other** measurements that Bethan must take in order to find the energy content of the bread. [2]

I.

II.

(ii) Why will the apparatus which Bethan uses not give an accurate reading of the energy content of the bread? [1]

.....

4461
02/00/09

5. John grew some seedlings in small flower pots in a school laboratory. When the shoots were long enough he placed one of the pots on a supporting box on a bench and illuminated the shoots **from one side only** using a powerful bench lamp.

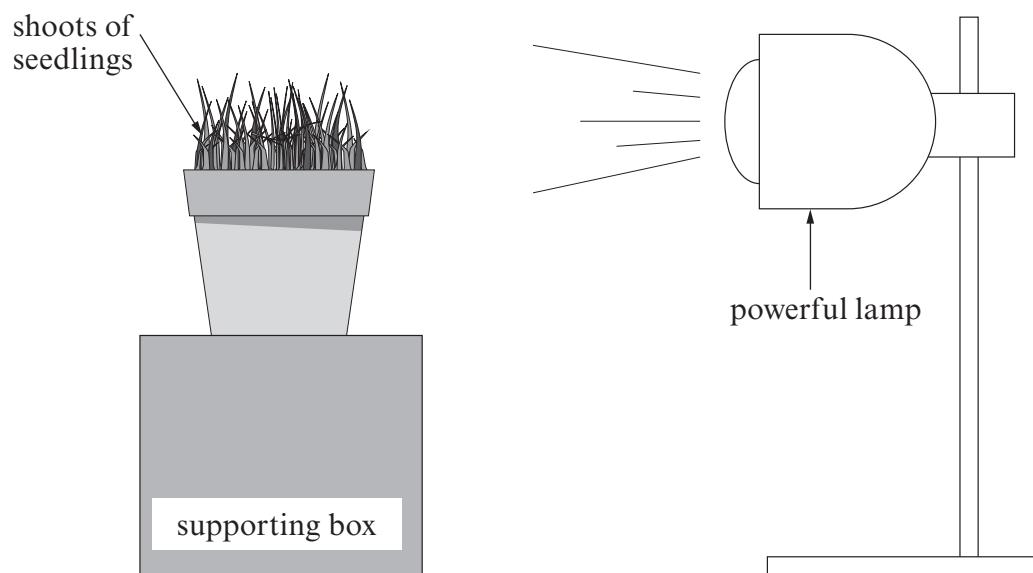

- (a) (i) After 48 hours John examined the shoots of the seedlings. State how the appearance of the seedlings will have changed. [1]
-
- (ii) State the name of the response shown by the shoots of the seedlings. [1]
-
- (iii) Name the group of chemicals that controls this type of response. [1]
-

- (b) John placed another pot of seedlings on a rotating plate. The plate completed one revolution every 20 minutes. The seedlings were illuminated **from one side only** by a powerful bench lamp.

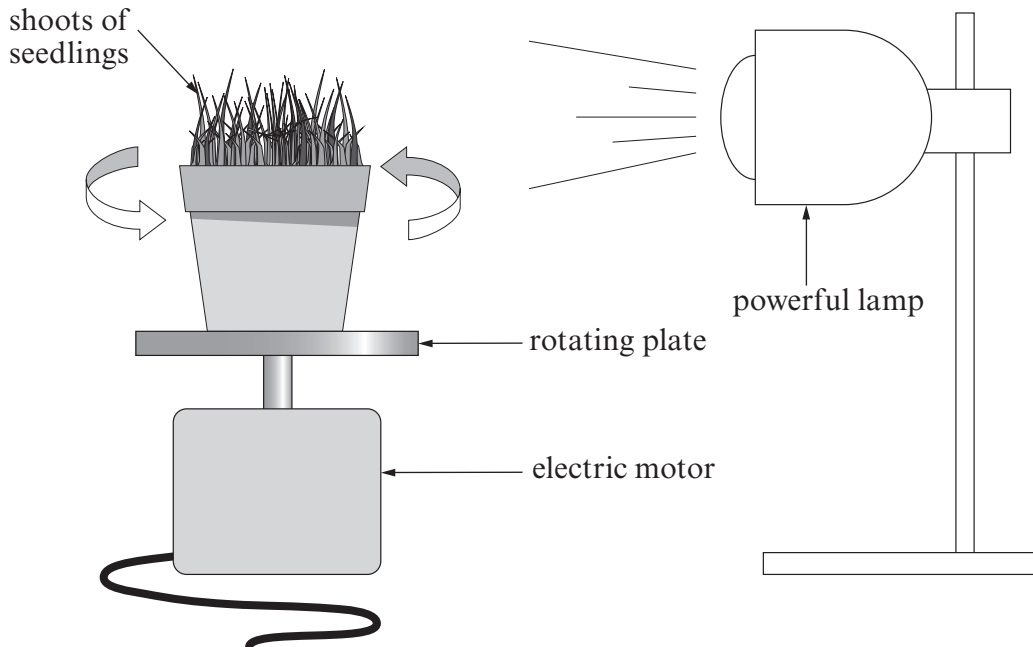

- (i) After 48 hours John stopped the electric motor. When he examined the shoots of the seedlings he found that they were growing: [1]

Underline the correct answer.

- A. away from the light
 - B. towards the light
 - C. straight up.
- (ii) Explain your answer to (b)(i). [2]

.....

.....

.....

4461
02/00/11

6. The flow chart below shows the relationship between glucose and insulin concentrations in the blood of a person.

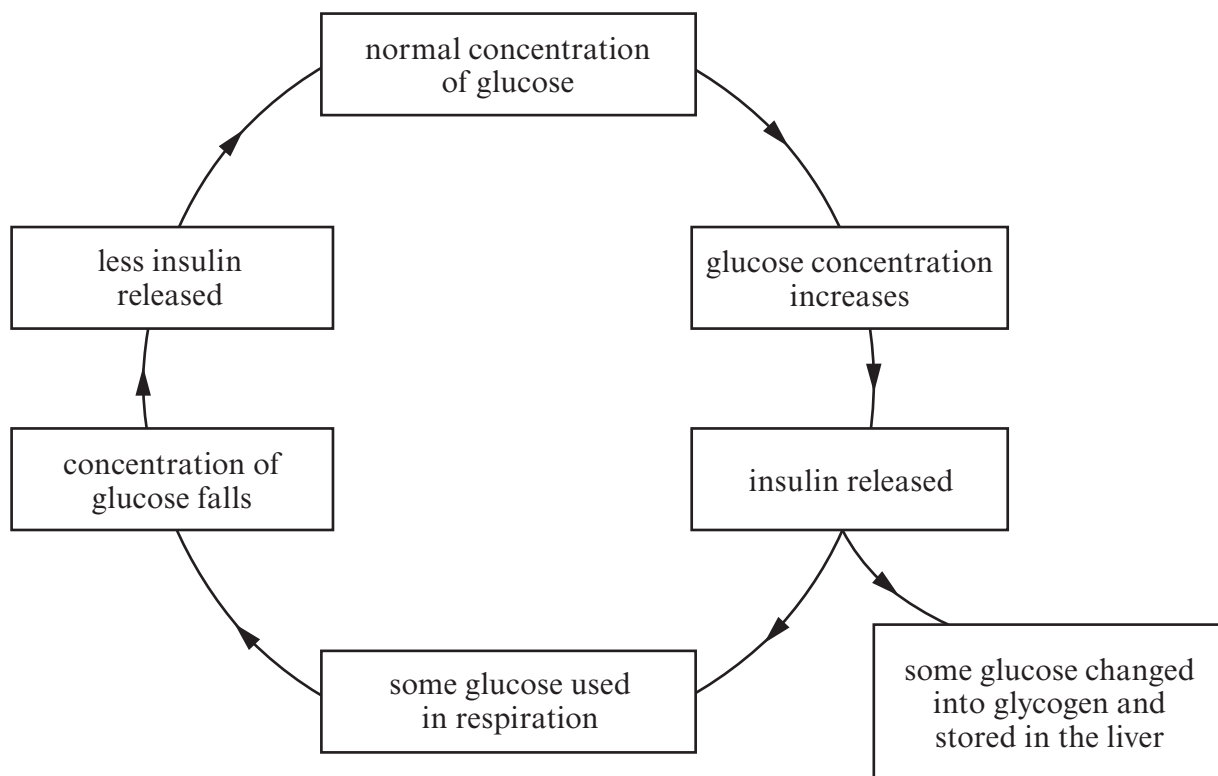

- (a) Write the word **EAT** on the flow chart to show clearly when the person eats a meal. [1]
- (b) Suggest why some of the glucose is changed to glycogen and stored in the liver. [1]
-
-
- (c) Mark with an **X** on the flow chart, the box which would **not** be true in a person with Type 1 diabetes. [1]
- (d) What term is used to describe the control mechanism shown in the flow chart? [1]
-

BLANK PAGE

7.



A Soya crop

The flow chart below shows the principles of a process used to improve crop plants by genetic modification **IN THE CORRECT ORDER**.

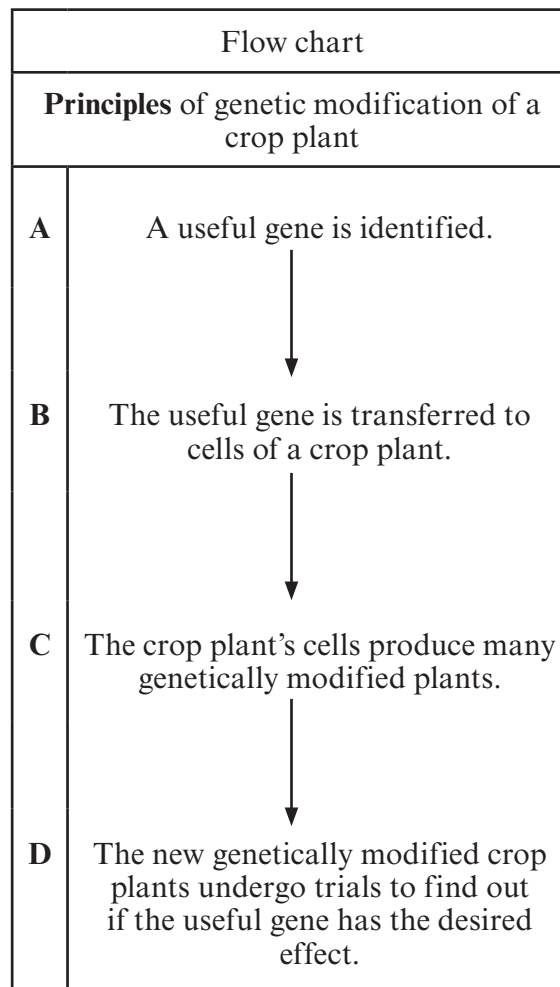

The table below lists the stages used in the genetic modification of soya. The stages are listed in the **WRONG ORDER**.

Stages in the genetic modification of soya	Letter
Soya plants of the new variety are tested in the field to find out if they resist herbicides.
Whole soya plants are grown from genetically modified cells of soya plants.
<i>Agrobacterium tumefaciens</i> infects soya plant cells passing on the gene which controls herbicide resistance.
<i>Agrobacterium tumefaciens</i> has a gene which controls herbicide resistance.

(a) Use the letters **A, B, C** and **D** shown in the flow chart opposite to complete the table above, matching the **principles** with the **stages** in the genetic modification. [3]

(b) State **one** reason why farm scale field trials are needed before a genetically modified crop is grown. [1]

.....

.....

8. Cystic fibrosis is an inherited condition that mainly affects the lungs. People with cystic fibrosis cannot make a type of protein.

(a) Cystic fibrosis is controlled by a pair of alleles. If one allele is found on one chromosome of pair number 7, where exactly would you find the second allele? [2]

.....

.....

(b) During gene therapy, people with cystic fibrosis have been treated by having normal alleles transferred into their lungs.
The first attempts at this treatment used micro-organisms called viruses to carry normal alleles into the lung cells.

(i) Suggest a possible problem as a result of using viruses to carry normal alleles into the lung cells. [1]

.....

(ii) Lung cells wear out and are replaced by new lung cells.
Suggest why this could be a problem for this type of gene therapy. [1]

.....

.....

(c) Explain how the results of a DNA profile could help inform people who intend to become parents and who have a family history of cystic fibrosis. [2]

.....

.....

BLANK PAGE

9. An investigation was carried out to find out how much fertiliser is wasted when it is sprayed on crops. The diagram shows the apparatus used.

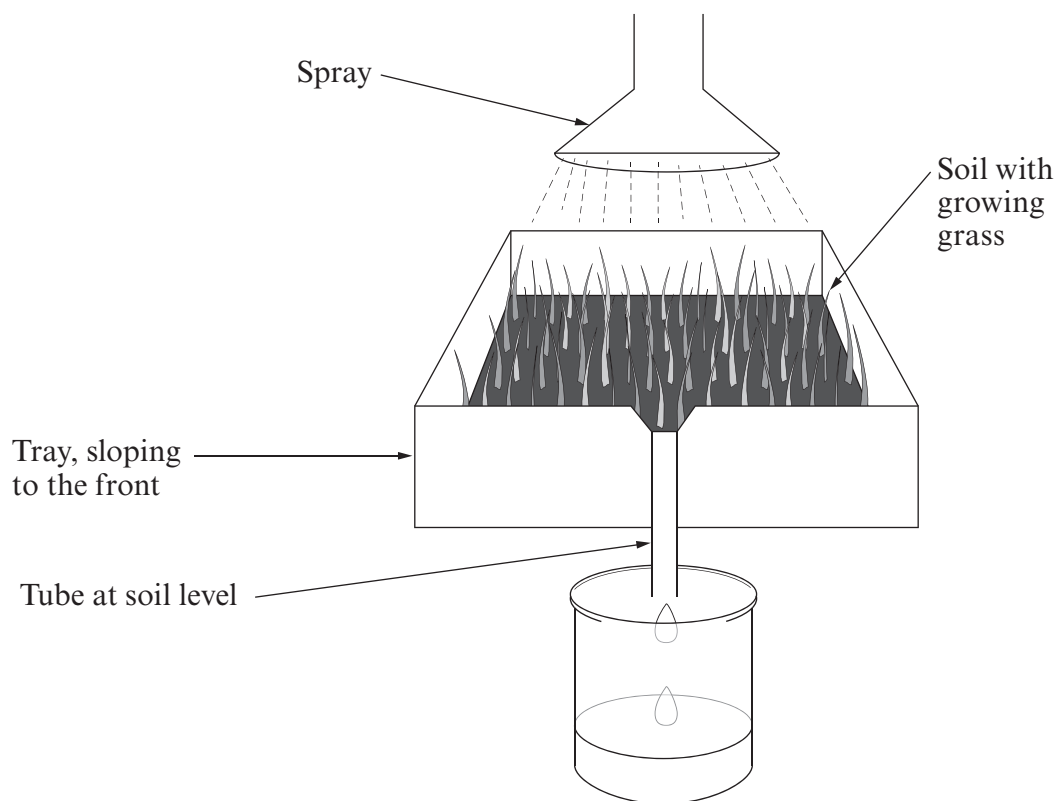

10 litres of a solution of fertiliser were sprayed on the tray for 1 hour. After 1 hour 7 litres of the solution had drained out of the tray.

- (a) Suggest **two** ways in which the investigation does not accurately represent the effects of spraying fertiliser on crops grown on a farm. [2]

(i)

(ii)

- (b) Suggest **two** plant nutrients present in artificial fertiliser. [1]

(i)

(ii)

Examiner
only

(c) Use the information given and your knowledge of the harmful effects of pollution to explain why some chemicals in fertiliser can harm fish in their natural habitat. [6 QWC]

.....

.....

.....

.....

.....

.....

.....

.....

.....

.....

.....

.....

.....

.....

10. Waste from a copper mine has been left near a river for a 100 years. Copper is a poisonous heavy metal. The map below shows the waste from the copper mine in relation to the river.

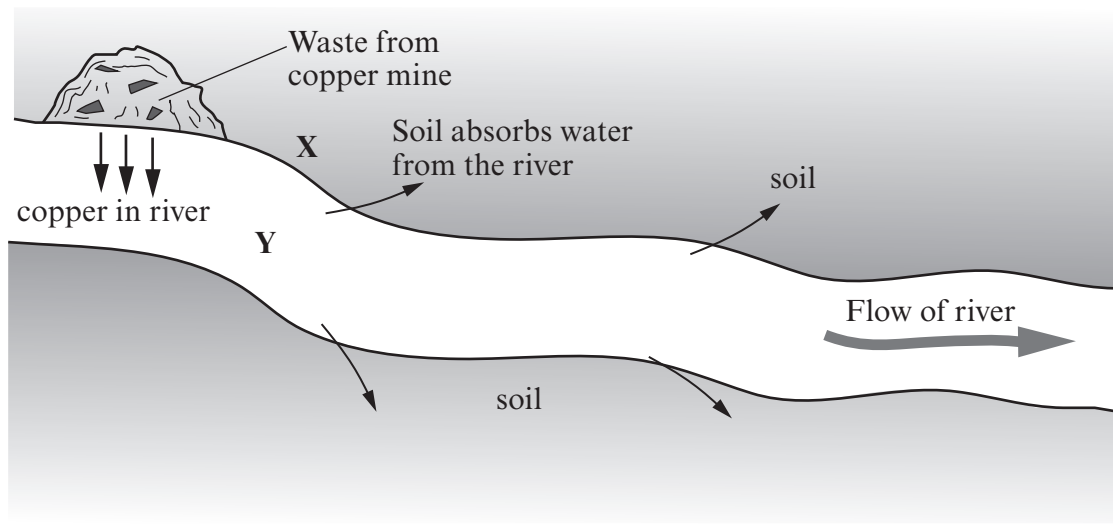

A sample of seeds from the grass *Agrostis tenuis* was collected at point X shown on the map and from 10 miles away from the river where there was no pollution from copper. Both samples of seeds were planted in soil and regularly watered with river water collected at point Y on the map. After three weeks the % seeds that had grown from both samples was recorded:

Seeds growing (%)	
Sample from point X	Sample from 10 miles away from the river
90	0.2

(a) State **two** factors other than time that would ensure that this was a fair test. [2]

- (i)
- (ii)

(b) Suggest how you would set up a control for this investigation. [1]

.....

.....

.....

Examiner
only

(c) Describe how natural selection can explain the results.

[4]

.....

.....

.....

.....

.....

THERE ARE NO MORE QUESTIONS IN THIS EXAMINATION.

7